

# SERIES 35-71

## 120 VAC Microprocessor-Based Direct Spark Ignition Control with Inducer Blower Relay

F-35-71  
March 2020

### FEATURES

- Safe start with DETECT-A-FLAME® flame sensing technology
- Custom pre-purge and inter-purge timings
- Inducer blower control and airflow switch monitoring
- Single or three trials for ignition
- System diagnostic LED
- Flame current test points
- Local or remote flame sensing
- Automatic reset
- Alarm output (normally closed contact)
- Open board, potted or enclosure
- Polarity insensitive input power

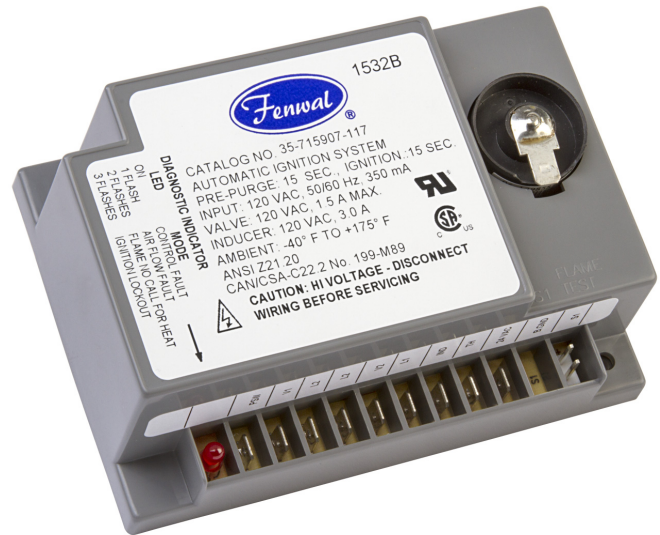

### APPLICATIONS

- Commercial cooking
- Agriculture
- Infrared burners
- Construction heaters
- Other gas-fired appliances

### DESCRIPTION

The 35-71 is a 120 VAC direct spark ignition (DSI) control designed for use in all types of gas-fired appliances. The control uses a microprocessor circuit to provide precise, repeatable timing and operating sequences. On-board diagnostics with LED output makes troubleshooting easy and ensures safe and efficient operation.

### Export Information (USA)

Jurisdiction: EAR  
ECCN: EAR99

### Agency Certifications

Recognized under the UL component program, UL 372. Software certified to ANSI/UL 1998. UL File MH8817

Design Certified to ANSI Z21.20, CAN/CSA C22.2 No. 199-M89

### SPECIFICATIONS

Input Power	102 to 138 VAC, 50/60 Hz
Input Current	350 mA @120 VAC with gas valve relay energized (control only)
Gas Valve	1.5A max @ 120 VAC
Inducer Blower	3.0 FLA @ 120 VAC
Operating Temperature	-40°F to +160°F (-40°C to +71°C)
Storage Temperature	-40°F to +185°F (-40°C to +85°C)
Flame Sensitivity	1.0 µA minimum
Flame Failure Response	0.8 seconds maximum
Flame Detector Self-check Rate	Once per second minimum
Gas Types	Natural, LP, or manufactured
Spark Rate:	
Remote	50/60 sparks/sec
Local	25/30 sparks/sec
Size (LxWxH) with enclosure	5.11 x 3.55 x 2.00 inches (12.98 x 9.02 x 5.08 cm)
Moisture Resistance	Conformal coated to operate non-condensing to 95% R.H. Module should not be exposed to water
Ingress Protection	Not rated, protection provided by appliance in which it is installed
Tries for Ignition	One or three try versions available
Trial for Ignition Periods	4, 7, 10, 15 seconds available
Pre-purge and Inter-purge Timings	0, 5, 15 or 30 seconds available
Post-purge Time	0, 30 or 60 seconds available

---

## SEQUENCE OF OPERATION / FLAME RECOVERY / SAFETY LOCKOUT

### Power Up / Stand By

Upon applying 120VAC power to L1, the control will reset, perform a self-check routine, flash the diagnostic LED and enter the thermostat scan state.

### Start Up - Heat Mode

When a call for heat is received from the thermostat supplying 120 VAC to TH, the control will check the pressure switch for normally open contacts. The inducer blower is then energized. Once the pressure switch contacts close, a pre-purge delay begins. Following the pre-purge period, the gas valve is energized and sparking commences for the Trial for Ignition (TFI) period.

When flame is detected during the TFI, the sparking process is terminated and the gas valve and inducer blower remain energized. The thermostat, pressure switch and burner flame are constantly monitored to ensure proper system operation. When the thermostat is satisfied and the demand for heat terminates, the gas valve is immediately de-energized. The control verifies the loss of flame signal and initiates an optional post-purge period before de-energizing the inducer blower.

### Failure to Light - Lockout

#### SINGLE TRIAL MODEL

Should the burner fail to light, or a flame is not detected during the TFI period, the gas valve will de-energize and the control will go into lockout. The inducer blower will turn off following the optional post-purge period. The LED will indicate the fault code for ignition lockout.

#### MULTI TRIAL MODEL

Should the burner fail to light or the flame is not detected during the TFI period, the gas valve will de-energize. The control will then go through an inter-purge delay before an additional ignition attempt. The control attempts two additional ignition trials before de-energizing the gas valve and entering lockout. The inducer blower will turn off following the optional post-purge period. The LED will indicate the fault code for ignition lockout.

#### FLAME FAILURE - RE-IGNITION MODE

If the established flame signal is lost while the burner is operating, the control will respond within 0.8 seconds by immediately energizing the spark for the TFI period in an attempt to relight the flame. If the burner does not light within the TFI, the gas valve will immediately de-energize and single try models will enter lockout. On multi-try models, a new TFI sequence will begin after an inter-purge delay. Multi-try models perform two additional attempts to light the burner. If the burner relights, normal operation resumes. If the burner does not relight, the control will enter lockout and the inducer blower will turn off following the optional post-purge period.

#### FLAME FAILURE - RECYCLE MODE

With the "Recycle After Loss of Flame" option, upon loss of flame, the gas valve is de-energized and the control proceeds to inter-purge before attempting to relight the flame. Multi-try models permit three tries for ignition including inter-purges. If the burner relights, normal operation resumes. If the burner does not relight, the control will enter lockout and the inducer blower will turn off following the optional post-purge period.

### Lockout Recovery

Recovery from lockout requires a manual reset by either resetting the thermostat, or removing 120 VAC for a period of 5 seconds. On models with automatic reset, if the thermostat is still calling for heat after one hour, then the control will automatically reset and attempt to ignite the burner.

### Combustion Airflow Fault

Combustion airflow is continually monitored during an ignition sequence by the pressure switch (PSW). If during the initial call for heat, the switch contacts are in the closed position for 30 seconds, without the inducer blower being energized, the LED will indicate an airflow fault and remain in this mode with the inducer blower off. If the pressure switch contacts later open while there is still a call for heat, the control will begin the pre-purge period followed by a normal ignition sequence.

If the pressure switch remains open for more than 30 seconds after the inducer blower output (L1 & IND) is energized, the LED will indicate an airflow fault and the control will remain in this mode with the inducer blower on, waiting for the pressure switch to close. When proper airflow is detected at the pressure switch input (PSW) the control will begin the pre-purge period followed by a normal ignition sequence.

If the airflow signal is lost while the burner is firing, the control will immediately de-energize the gas valve and the LED will indicate an airflow fault. The inducer blower will remain on for the post-purge period and the control continues to monitor the PSW input waiting for airflow to return. If proper airflow is detected during the post-purge period, a normal ignition sequence will begin with the pre-purge period. Otherwise, the control will remain in an airflow fault as indicated by the LED with the inducer blower off.

## MOUNTING AND WIRING

The Series 35-71 control is not position sensitive and can be mounted vertically or horizontally. The control may be mounted on any surface and fastened with #6 sheet metal screws. Secure the control in an area that will experience a minimum of vibration and remain below the maximum ambient temperature of 160°F (71°C).

All connections should be made with UL Approved, 105°C rated, 18 gauge, stranded, .054" thick insulated wire. Refer to the appropriate wiring diagram when connecting the 35-71 to other components in the system.

 <b>CAUTION</b>	All wiring must be performed in accordance with both local and national electrical codes.
---	---

 <b>CAUTION</b>	Label all wires prior to disconnection when servicing controls. Wiring errors may cause improper and dangerous operation. A functional checkout of a replacement control should always be performed.
---	--

 <b>WARNING</b>	This product uses voltages of shock hazard potential. Wiring and initial operation must be performed by a qualified service technician.
---	---

 <b>WARNING</b>	Operation outside specifications could result in failure of the Fenwal Controls product and other equipment with potential for injury to people and property.
---	---

Terminal Designations			
Terminal	Description	Multi-Pin Connector P/N: TE 1-644615-1	Quick Connect (inch)
NC	Alarm	11	1/4"
V1	Valve Power	10	3/16"
PSW	Pressure Switch	9	1/4"
L2	120 VAC (Neutral)	8	3/16"
V2	Valve Neutral	7	3/16"
L1	120 VAC Input (Hot)	6	1/4"
IND	Inducer Output	4	1/4"
TH	Thermostat Input	3	1/4"
B. GND	Burner Ground	2	3/16"
S1	Remote Flame Sensor	1	1/4"
FC+, FC-	Flame Sense Test Points	2 Pin Header (TE P/N: 640383-2, Molex P/N: 26-60-2020)	

## Wiring Diagrams - 35-71

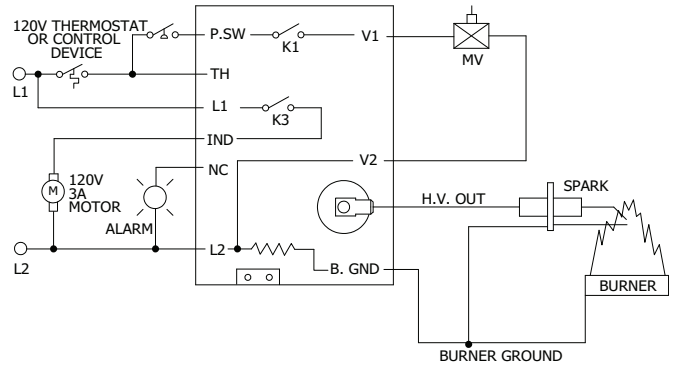

Figure 1. Local Sense

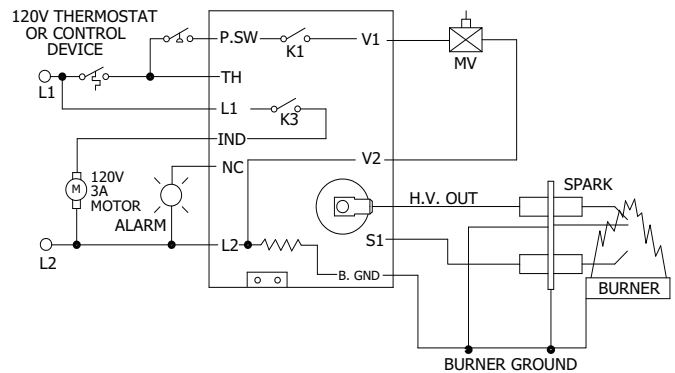

Figure 2. Remote Sense

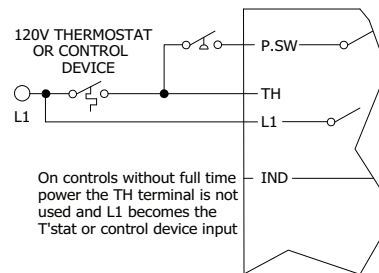

Figure 3. No Full Time Power

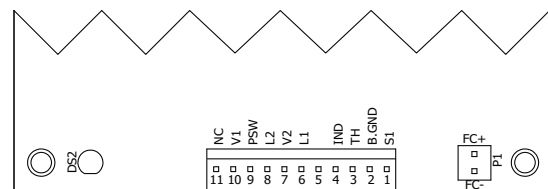

Figure 4. Pin Layout

## TROUBLESHOOTING

Troubleshooting Guide	
Symptom	Recommended Actions
1. Control does not start	A. Miswired B. No 120VAC at L1 C. Fuse or circuit breaker fault D. Faulty control, check LED for fault codes
2. Thermostat on - no spark	A. Miswired B. Faulty thermostat, no voltage at terminal L1 C. Faulty control, check LED for fault codes
3. Blower on - no TFI after purge delay	A. Miswired B. Flame fault C. Airflow fault (check voltage at PSW) D. Faulty control (check voltage between L1 and IND)
4. Valve on - no spark during TFI	A. Shorted electrode - establish 1/8-inch gap B. Check high voltage cable C. Miswired
5. Spark on - valve off	A. Valve coil open B. Valve wire disconnected C. Faulty control, check voltage at gas valve terminal V1
6. Flame okay during TFI - no flame sense after TFI	A. Check electrode position B. Check high voltage wire C. Poor ground at burner D. Poor flame, check flame current

Fault Conditions	
LED Indication	Fault Mode
Steady On	Internal Control Failure
1 Flash	Airflow Fault
2 Flashes	Flame without call for heat
3 Flashes	Ignition Lockout

**Note:** During a fault condition, the LED will flash on for 1/4 second and off for 1/4 second as needed to indicate the fault code. The code will repeat every 3 seconds. Removing power from the control will clear the fault code.

### Internal Control Failure

If the control detects a software or hardware error, all outputs are turned off and the LED displays a Steady On condition. If this condition persists after an attempt to restart, then the control must be replaced.

### Flame Fault

If a flame is sensed during a pre-purge or inter-purge, before the gas valve opens, a flame fault is declared and the inducer blower remains energized. If the flame signal later disappears, then the fault will be cleared and the control will start a normal ignition sequence.

### Proper Electrode Location

Proper location of electrode assembly is important for optimum system performance. The electrode assembly should be located so that the tips are inside the flame envelope and about 1/2-inch (1.2 cm) above the base of the flame as shown:

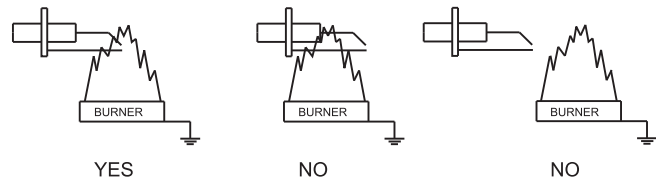

#### Notes:

- Ceramic insulators must not be in or close to the flame.
- Electrode assemblies must not be adjusted or disassembled. Electrodes are NOT field adjustable.
- Electrodes should have a gap spacing of  $0.125 \pm 0.031$  in ( $3.12 \pm 0.81$  mm), unless otherwise specified by the appliance manufacturer. If spacing is not correct, the assembly must be replaced.
- Exceeding temperature limits can cause nuisance lockouts and premature electrode failure.
- Electrodes must be located where they are not exposed during normal operation.

### Flame Current Measurement

Flame current is the current that passes through the flame from sensor to ground. To measure flame current, connect a True RMS or analog DC micro-ammeter to the FC+ and FC- terminals. Readings should be 1.0  $\mu$ A DC or higher. If the meter reads negative or below "0" on scale, meter leads are reversed. Re-connect leads with proper polarity.

Alternately, a Digital Voltmeter may be used to measure DC voltage between FC+ and FC- terminals. Each micro-amp of flame current produces 1.0 VDC. For example, 2.6 VDC equates to 2.6  $\mu$ A.

A good burner ground that matches the control ground is critical for reliable flame sensing.

# DIMENSIONS

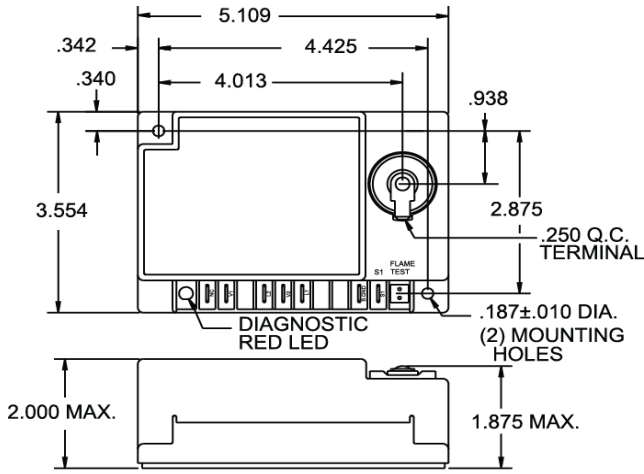

Figure 4. Enclosure

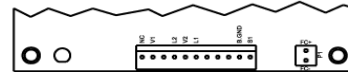
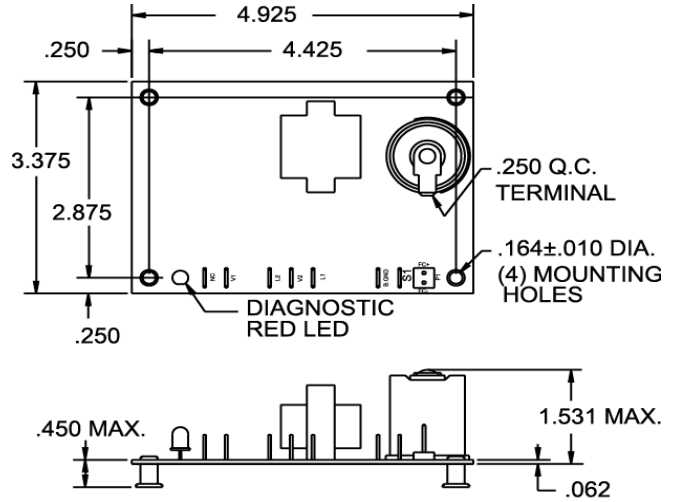

Figure 6. Integral Standoff

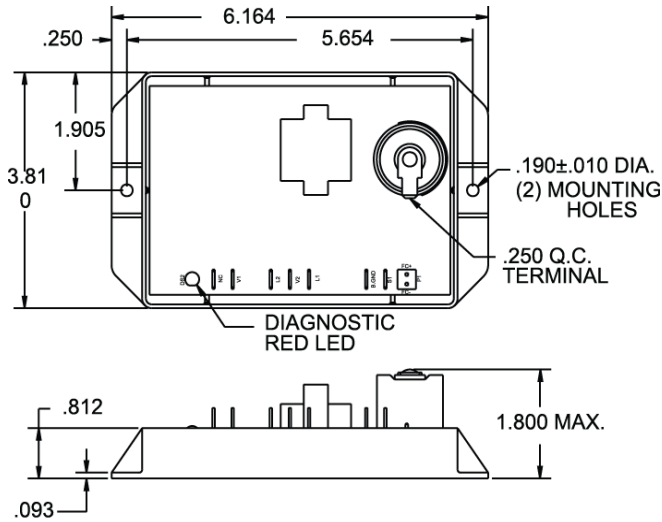

Figure 5. Potted

**Note:** All dimensions are in inches

# PART NUMBER CONFIGURATION

## SERIES 35-715 **X X X** - **X X X**

### Configuration and Wiring options

2 = Potted	Multi-Pin Connector
3 = Enclosure	Multi-Pin Connector
4 = Integral Standoffs	Multi-Pin Connector
5 = Enclosure	Quick Connect
6 = Integral Standoffs	Quick Connect
7 = Potted	Quick Connect
8 = Aftermarket Kit	
9 = Special Configuration	

An 8 or 9 in this location (i.e. 35-715 **901**-113) indicates a special configuration. 9XX is a sequentially assigned part number and does not follow the standard part numbering configuration.

Consult Fenwal Controls for operating characteristics of this control.

### Combustion Blower Control,

#### Post-purge time and Power Options

0 = 0 second post purge and no full-time power - Single 120 VAC input for both blower and thermostat

1 = 0 second post purge with full-time power  
 2 = 30 second post purge with full-time power  
 3 = 60 second post purge with full-time power

These options require individual 120 VAC inputs for blower and thermostat which allows higher current to feed the combustion blower without having to pass through the thermostat

### Trial for Ignition

1 = 4 Seconds
3 = 7 Seconds
5 = 10 Seconds
7 = 15 Seconds

### Inter-Purge

0 = None (Single Try Only)
1 = 15 Seconds
2 = 30 Seconds

### Pre-Purge

0 = None
1 = 15 Seconds
2 = 30 Seconds
5 = 5 Seconds

### Tries for Ignition, Flame Sense

#### Method and Reset Method

0 = 1 try, local sense	Thermostat / power off reset
1 = 1 try, remote sense	Thermostat / power off reset
2 = 1 try, local sense	Automatic reset
3 = 1 try, remote sense	Automatic reset
5 = 3 try, local sense	Thermostat / power off reset
6 = 3 try, remote sense	Thermostat / power off reset
7 = 3 try, local sense	Automatic reset
8 = 3 try, remote sense	Automatic reset

DETECT-A-FLAME is a registered trademark of Kidde-Fenwal, Inc., or its parents, subsidiaries, or affiliates.



Fenwal Controls, Kidde-Fenwal Inc.  
 400 Main Street  
 Ashland, MA 01721  
 Tel: 800-FENWAL-1  
 Fax: 508-881-7619  
[fenwalcontrols.com](http://fenwalcontrols.com)

This literature is provided for informational purposes only. KIDDE-FENWAL, INC. assumes no responsibility for the product's suitability for a particular application. The product must be properly applied to work correctly. If you need more information on this product, or if you have a particular problem or question, contact KIDDE-FENWAL, INC., Ashland, MA 01721.